

MODEL 8 series



NARROW WELD HEADS



Model 8-2000



Model 8-6625

The Model 8 series orbital weld heads are designed for fusion (TIG) welding of tube, thin-wall pipe and fittings through the range of 0.25" (6 mm) to 6.625" (168 mm) OD (outside diameter) and wall thicknesses up to 0.160" (4 mm). The narrow width of these heads makes them ideal for fitting-to-fitting welds and other limited-clearance applications.

The Model 8 series weld heads incorporate a two-sided clamping mechanism - precision machined and designed to compensate for significant diameter variances while ensuring positive clamping force and concentricity. The insert sizes accommodate an extensive range of applications and all Model 8 series weld heads are fitted with water-cooling capability - for heavy wall material welding and/or high duty-cycle requirements.



Model 8-4000

QUICK SPECS

	Model 8-2000	Model 8-4000	Model 8-6625
Tube/Pipe OD Range	0.25" - 2.00" 6,3 - 52 mm	0.50" - 4.00" 12,7 - 104 mm	2.00" - 6.625" 51 - 169 mm
Travel Motor	D.C., P.M., D.C. Tachometer		
Head Weight	6 lbs. (2,7 kg)	10 lbs. (4,5 kg)	17 lbs. (7,7 kg)
Electrode Size	1/16" and 3/32" (1,59 mm and 2,38 mm)		
Rotor RPM	0.1 - 10.0	0.1 - 10.0	0.1 - 2.0
Cable Length	25 ft. (7,6 m) when connected to adapter cable (included with Power Supply)		
Water Cooling	Recommended for heavy wall or high duty-cycle applications		
Compatible with all AMI Power Supplies.			



MODEL 8 SERIES NARROW WELD HEADS

OD RANGE/DIMENSIONS

Model No.	Tube/Pipe OD Range	Dimensions					
		A	B	C	D	E*	F*
8-2000	0.25" - 2.00" 6,35 - 52 mm	13.44" 341 mm	2.81" 72 mm	2.75" 70 mm	5.50" 140 mm	0.85" 21,6 mm	1.75" 44,5 mm
8-4000	0.50" - 4.00" 12,7 - 104 mm	16.25" 413 mm	3.87" 98,3 mm	3.75" 95 mm	7.50" 190 mm	0.85" 21,6 mm	1.75" 44,5 mm
8-6625	2.00" - 6.625" 51 - 169 mm	20.26" 515 mm	5.42" 138 mm	5.50" 140 mm	11.00" 280 mm	0.85" 21,6 mm	1.75" 44,5 mm

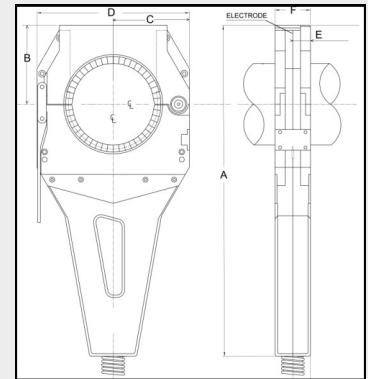

* "E, and F" dimensions with standard Model 8 clamp inserts

OPTIONAL ACCESSORIES

- Tungsten extender — to weld short stick-out components
- Fitting support mandrel — to facilitate the welding of short sanitary ferrules without pre-tacking
- Bench mount bracket — to provide secure support when not in use or when bench welding
- Clamp inserts — available in inch and metric sizes, as well as non-standard sizes for custom applications.
- Extension cables — available in 25 ft. (7,6 m), 50 ft. (15,2 m), and 75 ft. (22,8 m) lengths



Tungsten extender

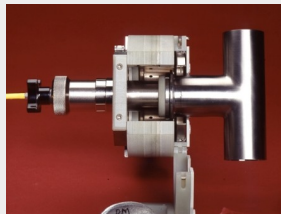

Fitting Support Mandrel

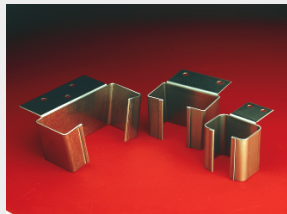

Bench mount bracket



Clamp inserts

The Global Welding Company

For further information please visit our website
or contact us at 1-818-896-9556



Dynamic. Growing. Integrated.

www.arcmachines.com

www.theglobalweldingcompany.com

HEADQUARTERS

Arc Machines, Inc.

10500 Orbital Way
Pacoima, CA 91331 U.S.A.
Tel: +1 / 818 / 896 / 9556
Fax: +1 / 818 / 890 / 3724
sales@arcmachines.com

SOUTHWEST OFFICE

Arc Machines, Inc.

10650 Haddington Drive
Houston, TX 77043 U.S.A.
Tel: +1 / 818 / 896 / 9556
Fax: +1 / 818 / 890 / 3724
sales@arcmachines.com

GERMAN OFFICE

Arc Machines GmbH

Markelsbach 2
D-53804 Much, Germany
Tel: +49 / 2245 / 91680
Fax: +49 / 2245 / 916868
sales@arcmachines.de

UK OFFICE

Arc Machines UK Limited

11 Low March
Daventry, NN11 4SD, UK
Tel: +44 / 1327 / 879606
Fax: +44 / 1327 / 315034
sales@arcmachines.co.uk

INDIA OFFICE

AMI India Pvt. Ltd.

G O Square, "B" Building,
1st Floor, Aundh - Hinjewadi
Road, Wakad
Pune - 411033 MH, India
Tel: +91 / 90110 / 24331
sales@arcmachines.com